

Altair SimSolid is a structural analysis software developed specifically for rapidly evolving design processes. It eliminates geometry simplification and meshing, the two most time-consuming and expertise-extensive tasks done in traditional FEA, enabling the analysis of fully-featured CAD assemblies in minutes without meshing.

Product Highlights

- Eliminate geometry simplification and meshing. With SimSolid, model preparation is done in minutes.
- Analyze complex parts and large assemblies. SimSolid is tolerant of imprecise geometry, and its assembly connections are industry best at handling ragged contact surfaces.
- Get results in seconds to minutes, SimSolid is fast, really fast. Hence, multiple design scenarios can be quickly analyzed and compared.

SimSolid can analyze complex parts and large assemblies not practical with traditional FEA and do it efficiently on a desktop class computer. Both fast and accurate, SimSolid controls solution accuracy using a unique multi-pass adaptive analysis.

The computational engine is based on breakthrough extensions to the theory of external approximations. External approximations are a generalization of Finite Element Method (FEM) in terms that:

- Absolutely arbitrary geometrical shapes can be used as “finite elements”
- Basis functions which approximate field of interest in the part volume can be of arbitrary class and are independent of the volume shape

SimSolid does not use the point-wise degrees of freedom (DOF) inherent in traditional FEA.

SimSolid's DOF are functionals with geometrical support in the form of volumes,

areas, line clouds, and point clouds. This provides the ability to handle geometrical imperfections, as well as assembly contact imperfections like gaps, penetrations and ragged contact areas.

SimSolid controls solution accuracy using multi-pass adaptive analysis. Adaptivity can be defined on a global or part local basis and adaptivity is always active. The methodology is fast and efficient. It provides superior performance metrics for computational time and memory footprint that allow very large and/or complex assemblies to be solved quickly on desktop class PC's.

Benefits

Eliminate Geometry Simplification and Meshing

SimSolid's unique technology completely eliminates geometry simplification and meshing, the two most time consuming, expertise extensive and error prone tasks

Learn more:
altair.com/simsolid

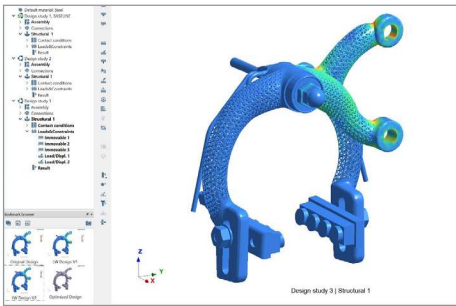

Early analyze complex shape data and evaluate multiple cases

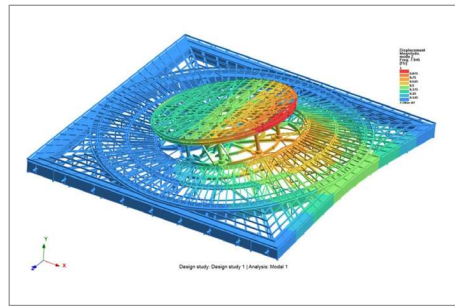

A complex assembly like this one, with 5200 parts, can be analyzed in minutes

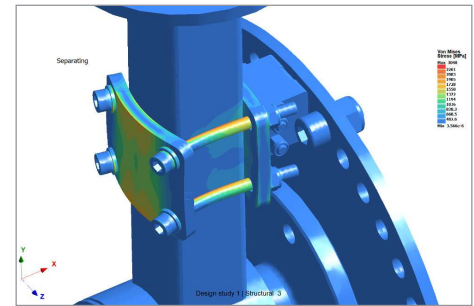

Nonlinear analysis accurately reproducing the contact between bolt and plate

done in traditional FEA. With SimSolid, model preparation is done in minutes.

Analyze Complex Parts and Large Assemblies

SimSolid has been designed to analyze complex parts and large assemblies not practical with traditional FEA. SimSolid is tolerant of imprecise geometry. Its assembly connections are industry best at handling ragged contact surfaces with both gaps and overlapping geometry.

Get Results in Seconds to Minutes

SimSolid is fast, real fast. Solution times are typically measured in seconds to minutes on a standard PC. With SimSolid, multiple design scenarios can be quickly analyzed and compared. And, accuracy can be specified on an individual part level allowing a rapid drill down to any level of detail that is required.

Capabilities

Analysis Solutions

The following simulation types are supported: linear statics, modal, nonlinear statics (material & geometrical), thermal, coupled thermal-stress, linear dynamics (time, frequency and random response).

Supported Connections and Boundary Conditions

- Assembly Connections: Smart auto connections, bonded, sliding, separating with friction, bolted, spot & laser welds, fillet/seam welds, virtual connectors
- Loads & BC's: Immovable constraint, sliding constraint, hinge constraint, enforced displacement, force, pressure, gravity, thermal, inertia relief, bolt/nut preload, dynamic loads, hydrostatic loads, bearing loads, and remote loads

Material Properties

- Isotropic
- Incompressible
- Elastoplastic with NL stress vs strain curves
- Rigid
- User extensible

CAD Connectivity

- Direct data integration to Cloud-based CAD systems
- Standard STL output from any CAD system
- Direct file support for mainstream CAD systems: CATIA, NX, Creo, SOLIDWORKS, Inventor and SolidEdge
- Direct file support for common neutral formats: STEP, ACIS and Parasolid, etc.

Post-Processing and Reporting Result types

- Contour plots with displacements, stress & strains
- Deformed shape animation
- Max/min labels
- Point probes
- XY plots
- Reaction/contact forces
- Bolt/nut forces
- Spot weld forces
- Frequencies and mode shapes
- Modal participation factors
- Safety factors

Reporting

- Image thumbnails and captions associated with model graphics state, part visibility, and results display
- Synchronized model and results browsing
- Results are exported as full resolution image files

General Usability

- Able to process mixed (SI and IPS) units
- Measurements (distance, ray probe, local coordinates)
- Global and local coordinate systems
- Default views (front, back, left, right, top, bottom)
- Custom saved views

“When we are ordering tons and tons of the raw materials for our chains, a pound here and a pound there starts becoming important, so that’s where we spend a lot of time trying to optimize our product. Applying SimSolid to this challenge in the long run will make us a lot of money.”

Bob Adams, Engineering Manager
Serapid, Inc.